

Ilco 790 Series

Access Control Systems

dormakaba

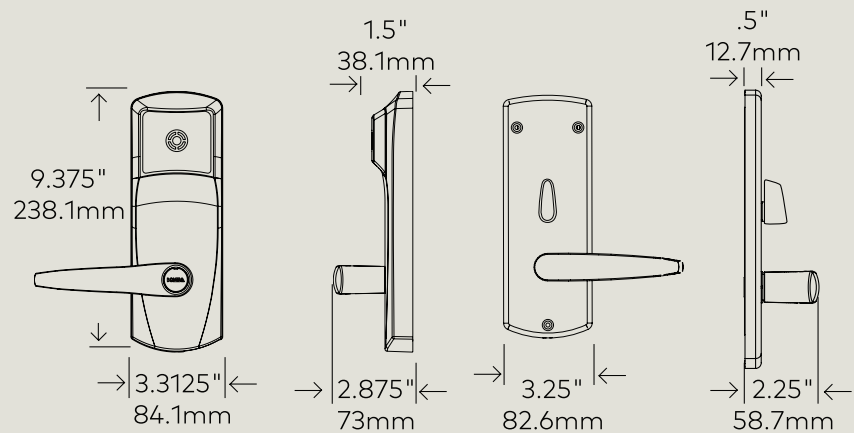

Overview

The Ilco 790 door lock offers RFID technology to enhance guest convenience and improve operational efficiency. This RFID solution offers keycard auditing capabilities for enhanced staff monitoring & user accountability. The Ilco 790 works with both the dormakaba access management software and portable device.

Applications

- Suitable for small to very large scale hotels
- Easily replaces existing mechanical or electronic door locks
- Access control for guest rooms, common areas, and back-of-house

Mobile Access

This Bluetooth Low Energy (BLE) capable lock can operate using the dormakaba Mobile Access Solutions.

Security Features

- High security and tamperproof design
- 1" solid deadbolt (optional auto deadbolt)
- Emergency access: Emergency keycard, mechanical key and electronic override

Low Maintenance

- Operates with a completely sealed contactless reader
- Batteries last up to 3 years
- Low battery indicator alerts staff
- Lock programming and audit are not erased during battery replacement
- Wear resistant construction and finish
- Upgradable lock firmware

Access Management Software

The 790 lock is supported by dormakaba's robust access management software solution that features an array of access control workflows for both guest and staff access. Optionally, choose dormakaba's online access management solution for better door management and monitoring.



Mechanical Features

Description	Heavy duty electronic lockset with clutch mechanism and built-in contactless RFID reader (mortise or cylindrical)	
Handing	Left or right factory handed mortise, field reversible handing (lever and mortise)	
Lever	<p>ADA compliant, outside lever free to rotate upward and downward in locked mode. Lever clearance (space from end of lever to door):</p> <p>Long Lever: 3/8" (9.5mm) Short Lever: 2" (51mm) Elevon & Gala Lever: 2" (58mm)</p>	
Concealed Key Override (optional)	Ilco KIK Core (keyed-alike, master keyed, recodable) Best small IC adaptor	
Deadbolt	1" (25 mm) (for ASM mortise) or 2 1.4 mm (for ESM mortise) solid metal, projected by inside thumbturn and retracted with the latch by the interior handle, emergency override or specific staff keycards. Optional auto deadbolt available	
Door Thickness	From 1 3/8" to 2 1/2" (35mm to 66mm)	
Shipping Weight	8.5 lbs (3.8 kg)	
Housing Construction	Cast zinc alloy (outside housing levers and thumbturn), stainless steel inside housing	
Standard Finishes	Satin chrome, satin brass and ultra finish for ocean front applications	
Standard Backset	2 3/4" (70mm) backset, 2 3/8" (60mm) backset also available for cylindrical lock	
Locking Options	ANSI lock case with 1 1/4" or 1" lock front mortise. Optional automatic deadbolt Cylindrical latch (2 3/8" or 2 3/4" backset) European lock case mortise [20 x 165 mm] with round (20 or 23 x 235 mm) or square (20 x 235 mm) lock front mortise	

Mobile Access Options

BLE ready	Upgradable to BLE with BLE module
BLE enabled	End cap with BLE module included, no further upgrades needed

Batteries

Alkaline	3 AA batteries for up to 120,000 openings or up to 3 years (based on 10 openings per day). Low battery indicator: alerts staff that batteries need to be changed soon
----------	---

Lock Operation

Date/Time Stamp	Real time: date and hours/minutes
Programming and Audit Trail Downloading	Can be done using a 4K audit keycard or by using dormakaba M-Unit or FDU
Pre-registered Keycards	Up to 10 days in advance
Keycard Expiry	From 1 hour to 7 years, depending on type and setup
Passage Mode	Set by authorized keycard
Lockout Mode	Set by authorized keycard
Keycards Accepted	RFID cards or tags (ISO 14443, Mifare Classic (4 Byte NUID))
Feedback	"Dual sensory" audible and visible indicators
Diagnostics	Built-in battery voltage meter and lock version display
Audit Memory	Last 2000 transactions stored in lock (lock audit can be retrieved using M-unit or FDU or using lock audit keycard)
Disability Feature	Extended unlock time (4 seconds standard, 15 seconds for disability)
Privacy Override	Default emergency keycard only (user selectable)

Certification and Testing

Accessibility Standard	ADA compliant levers (Code of Federal Regulations 28 CFR Part 36 – 1994 "ADA Standards for Accessible Design")
BHMA/ANSI	Certified to be compliant with Grade One performance tests for "ANSI/BHMA A156.13-2005 Standard for Mortise Locks and Latches," and "ANSI/BHMA A156.25-2007 Standard for Electrified Locking Devices." (Only locks tested and approved by non-biased third-party test lab are allowed in the "BHMA Certified Products Directory" found at www.buildershardware.com)
Fire Rating	Listed for pre-prepared manufactured doors and certified for retrofitting on existing doors by Underwriters Laboratories for use on fire doors having up to a three-hour rating. U.L. Certification: "Accessories for Single-point Locks and Latches and Fire Exit Hardware." Evaluated in accordance with UL 10B and UL 10C. U.L. Listing: "Electrically Controlled Single-point Locks and Latches." Evaluated in accordance with UL 10B and UL 10C. Also classified in accordance with Uniform Building Code Standard 7-2, "Fire Test of Door Assemblies" (1997)
Electronics	FCC Part 15 Class A and CE directive 89/336/EEC compliant
Environmental Operating Conditions	-31°F to 151°F (-35°C to 66°C) 0% to 85% non-condensing humidity at 86°F (30°C)
Florida Building Code	Approved in the exterior door category (exterior door components). Code of approval is FL13061

Warranty

Standard Factory	Two years
Support Programs	dormakaba Service Plans (Platinum, Gold, Silver)

