

## Letterbox set 1909,ABM=25

For locking lever cylinder with standard system length 25 mm

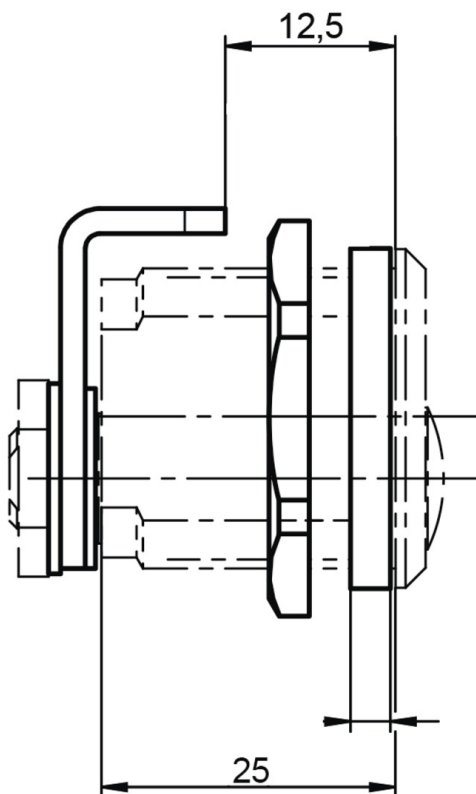

### Product description

- Individual components for installation of letterboxes
- System consists of: 2 rings, 1 housing nut, 1 locking lever 1645069, 2 shims P512x18x1 and 1 retaining washer S12

### Scope of delivery

- 1 letterbox set

### Note

- Suitable for IKON 5-pin locking lever cylinders (systems TK5 and SK5)

### Suitable ASSA ABLOY products

- Locking lever cylinder .320,AUS=1/..30
- Locking lever cylinder .320,AUS=2

### Variants that can be ordered

#### Article number

1909 40488